

# SMARTPHONE IV

## Simplified Programming Instructions

### Basic Programming 1 - 3. Advanced Programming 4 - 7.

Phone has been preset to Standard *SMARTPHONE IV* Operation.  
The following steps can be done in any order.

#### 1. Programming Telephone

- Press START
- Press SET (key in telephone number)
- Press M1
- Press SET (key in telephone number)
- Press M2
- Press and hold STOP for 2.5 seconds

#### 2. Programming Call Tracker

- Press START
- Press START
- Speak message – 18 seconds
- Press STOP
- Press PAUSE to review message
- Press and hold STOP for 2.5 seconds

#### 3. Programming Timer

- Press START
- Press SET, SET
- Enter the number of minutes you wish to talk
- Press SET
- Press and hold STOP for 2.5 seconds

#### 4. Change Telephone Security Code

- Press START
- Press SET, SET, SET
- Press 2
- Press 4 digit ID Code (your decision) Note this on label.  
Cannot be 0000.
- Press STOP
- Press and hold STOP for 2.5 seconds

#### 5. Ring – Down Telephone Line Programming

- Press START
- Press SET, PAUSE, M1
- Press SET, M2
- Press SET, SET, SET
- Press 3
- Press 0
- Press STOP
- Press and hold STOP for 2.5 seconds

#### 6. Programming Consolidator Telephone ID Numbers

- Press START
- Press SET, SET, SET
- Press 1
- Key in the number for the elevator (i.e. 1-5)
- Press STOP
- Press and hold STOP for 2.5 seconds

#### 7. Consolidator Operation

Dial the *SMARTPHONE IV*, all phones will automatically answer active.

##### 1. Select Individual Phone

- |                     |                      |
|---------------------|----------------------|
| Press * 1 (Phone 1) | Press # 1 (Phone 6)  |
| Press * 2 (Phone 2) | Press # 2 (Phone 7)  |
| Press * 3 (Phone 3) | Press # 3 (Phone 8)  |
| Press * 4 (Phone 4) | Press # 4 (Phone 9)  |
| Press * 5 (Phone 5) | Press # 5 (Phone 10) |

##### 2. Select All Phones Press \* 0

(2-way conversation with all units)

##### 3. Select All Phones (page mode) Press \* 9

(Listen mode only, in elevator)

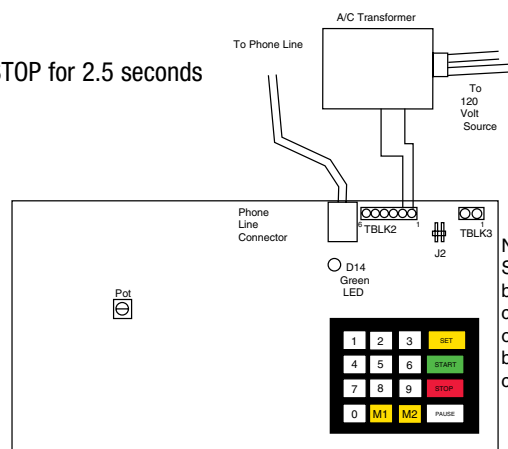

Note:  
SMARTPHONE IV can be programmed without connection to 110 V AC or the telephone line when back-up battery is fully charged.

**continued** ►



We're There for You!  
TOLL FREE TECHNICAL SUPPORT 1-800-451-1460 EXT. 3

## Step 1 Remote Programming Sequence

### 1. SMARTPHONE IV Standard Remote Programming

- Call number of phone or phones.
- After you get the simulated ring, press the # key twice. Will hear long deedoodeedoo tone.
- Key in the security code (4 digits). Will hear deedoodeedoo tone. Wrong security code will terminate the call.
- Press 9\*0. Will hear tone. All phones will be ready to program. See Table A for programming menu.
- Press 9\*# to end programming

### 2. SMARTPHONE IV Consolidator Mode Remote Programming

- Call number of phone or phones.
- After you get the simulated ring, press the # key twice. Will hear long deedoodeedoo tone.
- Key in the security code (4 digits). Will hear deedoodeedoo tone. Wrong security code will terminate the call.
- Changing a single phone or all in group:

#### A) Single Phone

- After security code, press 9\*1. Will hear deedoodee tone. This will make phone with ID 1 ready to program.
- See Table A for programming menu.
- Press 9\*2. Will hear deedoodee tone. You are now ready to program phone with ID 2. See Table A.
- Continue this until you have programmed all in the group.
- Press 9\*# to end the programming.

#### B) Changing All Phones In A Group

- After security code, press 9\*0. This will make all phones ready to program.
- See Table A for programming menu.
- Press 9\*# to end the programming.

**TABLE A**

1 #	(ENTER PHONE NUMBER M1, * for pauses)	# Deedoodee
1 *	Phone number M1 is played back in beeps	Deedoodee
2 #	(Enter phone number M2, for pauses)	# Deedoodee
2 *	Phone number M2 is played back in beeps	Deedoodee
3 #	(Enter timeout minutes, last three digits) <i>Factory set at 15 minutes</i>	# Deedoodee
3 *	Timeout minutes played back in beeps	Deedoodee
4 #	Record Message # to stop	Deedoodee
4 *	Message is played back	Deedoodee
9 * #	Will terminate call	

We're There for You!

TOLL FREE TECHNICAL SUPPORT 1-800-451-1460 EXT. 3



N56 W24720 N. Corporate Circle, P.O. Box 306 Sussex, Wisconsin 53089

800-451-1460 FAX 262-246-4828

Web site: [www.rathmicrotech.com](http://www.rathmicrotech.com)

Sales: [info@rathmicrotech.com](mailto:info@rathmicrotech.com)

Tech Support: [help@rathmicrotech.com](mailto:help@rathmicrotech.com)